

# INCREASING GENERIC ENGINEERING COMPETENCES USING COACHING AND PERSONAL FEEDBACK

Ivan H.H. Jørgensen and Niels Marker-Villumsen

Technical University of Denmark, Dept. of Electrical Engineering, Bldg. 349,  
DK-2800 Kgs. Lyngby, Denmark  
ihhj@elektro.dtu.dk, nbvi@elektro.dtu.dk

## ABSTRACT

This paper presents the implementation of a new course in analog integrated circuit design at the Technical University of Denmark. The course deals with many of the practical aspects of doing integrated circuit design and is designed using constructive alignment. In the paper, the intended learning objective, teaching activities and the assessment are presented and it is demonstrated how coaching and personal feedback – often used in the industry – is used to improve the generic engineering competences of the students in alignment with CDIO. The course is conducted as if it was a project in a company using a minimum of traditional lectures. The central teaching activities in the course are the status meetings, a review meeting and the time the student use for the actual design task. During these activities the teacher mainly acts as a facilitator for the students using coaching and a four step problem solving methodology. In order to create an environment for the students to practice their generic engineering competences they are throughout the course provided personal feedback by the teacher using a four step feedback model. The course was evaluated using the Course Evaluation Questionnaire (CEQ) and the overall score was 4.3 out of 5.

## KEYWORDS

Course planning, personal feedback, problem solving, generic engineering competences, Standards: 2, 4, 5, 6, 7, 8 and 11

## INTRODUCTION

Teaching the students the technical skills of engineering has for many years been the main focus at technical universities at the expense of teaching the student more generic engineering skills. This problem has increased over the last 1-2 decades as the need for deeper technical insight has increased in a world of rapid development. As a response to this the CDIO concept of teaching has been developed where focus on improving the generic engineering competences of the students is incorporated in the teaching without compromising the technical skills of the students. None-technical learning outcomes (CDIO, standard 2) like inter-personal and human behavior is however not as easy to asses as the technical skills since these often rely on a subjective evaluation by the teacher. Also, these skills are difficult to evaluate in a time limited examination and are best observed and evaluated throughout the course.

In this paper the development, using constructive alignment (Biggs et al, 2011), (Biggs, 2003), of a new master level course at the DTU is described. The course teaches a curriculum not previously taught at DTU and is designed to improve both the technical and generic skills of the students and it is discussed how the environment for learning is created and how the students are assessed. In this new course the students are to design a circuit in an integrated circuit (IC) for a given specification. The course is conducted as a project in a company and has a large focus on the development of the engineering competences of the

students. In order for the students to train their generic engineering competences (Crawley et al., 2007) throughout the course it is mandatory for the students to participate actively. Two major conditions made this possible in the course. First, an environment was created where the students felt safe to participate and not at least safe to make mistakes. This was done by only assessing the students by a final written report and clearly communicating that it is a natural part of engineering development make fails as long as the students can show that they learn from these errors and mistakes. Second, the students are not formally assessed on the generic engineering competence but throughout the course they are provided personal feedback by the teacher on these using a 4-step feedback model. In the paper these two conditions and the motivation behind them are discussed in detail. In the course special attention is given to enhance the problem solving skills of the students as this is an essential skill in basically all engineering work. For this a 4-step problem solving methodology is introduced to the students and teacher use this methodology to coach the student during the design phase. The course setup, the coaching and the personal feedback (explained in detail later) ensures that CDIO standards 4, 6, 7, and 8 are incorporated in the course.

In the following section a brief introduction to course planning using constructive alignment is given. After this the design of the new course is discussed in detail and it is described which of the CDIO standards that are incorporated in the course. Next, the results of the course evaluation using the Course Experience Questionnaire (CEQ) is presented and it is discussed how the course and the teaching activities support improving the engineering competences of the students.

## DEVELOPMENT OF COURSES USING CONSTRUCTIVE ALIGNMENT

Over the last decade there has been an increasing focus on higher learning at universities and a large amount of research has gone into learning how students learn (Biggs et al., 2011) and (Biggs, 2003). To design a course many approaches exist and here constructive alignment (Biggs et al. 2011 and Biggs 2003) is used. Constructive alignment uses three elements in the course planning (intended learning objectives, teaching activities and assessment) with the primary focus to increase student learning and competences as illustrated in Figure 1. In the following the three elements in the course planning is described as a sequential process but in practice it is an iterative process where the three elements are revisited until they are aligned. Also, the three elements should be revised after the final course evaluation to ensure that the student learning and intended learning objectives (ILOs) are aligned.

### *The Intended Learning Objectives*

The first step in planning the course is to identify the intended learning objectives (ILO) in

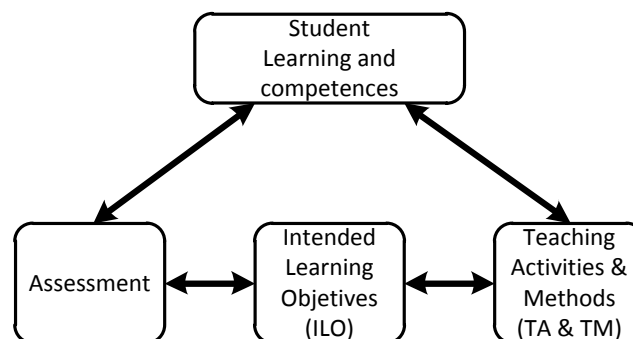

Figure 1. A model for constructive alignment (Biggs et al., 2011).

alignment with CDIO standard 2 and Biggs (2003). The ILOs are short statements of what a student will be able to do if they are met, i.e., what one would like the students to learn. For the teacher the ILOs serve two purposes. First, the ILOs greatly help to plan the course and the teaching activities (TA) as they serve as the goal for the teaching. Second, at the end of the course they are also very useful when designing an examination and finally when assessing the students. When formulating the ILOs it is important to ensure that they address both lower and higher level learning, e.g., according to the SOLO (Biggs et al 2011) or Bloom's taxonomy (Biggs et al., 2011), (Biggs, 2003) and (Felder et al., 2004). The students also have great use of the ILOs, e.g., in case a written report is the basis for the assessment then the ILOs show the student the topics to cover in the report.

### ***The Teaching Activities and Teaching Methods***

Once the ILOs are made the teaching activities are planned and along with these the teaching methods (TM) are chosen. The TMs are the principles used to teach whereas the TAs are the actual activities planned in the course. The most commonly used TA at universities are lectures, problem solving sessions and project work but they can in principle be anything like excursions, quizzes, etc. A large variety of teaching methods exist, e.g., inductive learning, problem based learning, learning by inquiry etc.

After choosing the TAs and TMs they are mapped against the ILOs to ensure that all ILOs are covered and thereby ensure the basis for student learning.

The TAs and TMs chosen naturally depend on the size of the classes. Classes with a large number of students cannot be taught on an individual basis and thus lectures and problem solving sessions are often used in this situation. Classes with few students offer the opportunity to teach the students individually or in small groups and thereby use many different teaching methods as will be illustrated in the example later in this paper.

### ***Assessment***

Based on the TAs and the ILOs it is decided how the level of formative and summative assessment (Biggs et al., 2011), (CDIO standard 11) should be implemented in the course. Here the ILOs again hold a central role for both the students and the teacher. E.g., if a written examination is prepared one should try to cover all the areas stated in the ILOs and summative grading is typically used. This is in contrast to formative assessment which is better suited for providing the students personal feedback on their learning and generic engineering competences (Crawley et al., 2007). Finally, part of the assessment is also to decide how to grade the student, i.e., by grades of pass/fail.

## **A NEW EXPERIMENTAL COURSE IN ANALOG INTEGRATED CIRCUIT DESIGN**

At universities the fundamental theory of analog integrated circuit (IC) design is often taught in traditional lecture courses but doing analog integrated circuit design has many more aspects to it. The circuit components that one use are very complex and vary a lot from IC to IC and also a lot of unwanted parasitic components appear in the physical design. Furthermore, the flow for doing analog integrated circuit design is complex (see Figure 2) and requires the use of a large variety of software tools. Besides having a good fundamental understanding of circuit design a good portion of craftsmanship is therefore needed in order to excel analog integrated circuit design.

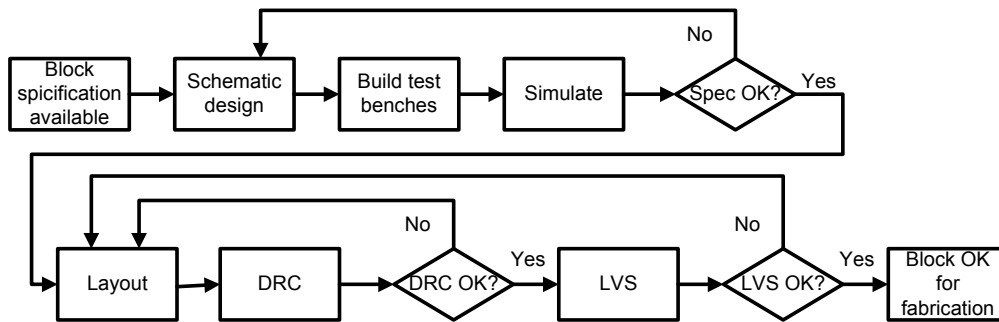

Figure 2. Simplified flow for integrated analog IC design.

At the DTU a new course has been designed that aims to add the practical aspects and craftsmanship of analog integrated circuit design to the portfolio of competences of the students. The curriculum of the course has not previously been taught at DTU. The course (Technical University of Denmark, 2014) is placed in the 3-week period where the students are working full time on a single course for 3 weeks. The planning and the evaluation results of the course are described in the following.

### **Course Vision**

The main idea behind the course is for the student to go through the flow of IC block design as described previously and subsequently fabricate their designs on a chip. Besides teaching the students the flow for IC block design, it is also the goal to strengthen the generic engineering competences of the students. To facilitate this, the course is constructed so it emulates a project being conducted in a company where the teacher is the manager and the student the employees.

### **The Learning objectives**

The ILOs, listed in Table 1, are formulated to cover the different elements in the flow for block design as shown in Figure 2. As part of the flow the students are expected to use all the software tools needed in the different parts of the flow, i.e., doing schematic design, using the simulation environment and using the verification tools; design-rule-checking (DRC) and layout-versus-schematic (LVS). As something new for the students they are asked to verify their design in all process corners (the variation in the component parameters).

The ILOs are formulated using different level of learning ranging from the lower level (e.g. “use” and “identify”) to higher level learning (e.g. “synthesize” and “analyze”). The different levels are used to emphasize that IC design requires a significant portion of craftsmanship and also relies on the systematic analysis and creativity used in the design phase. Also, by defining the ILOs at different levels they enable “not so skilled students” to pass the course while still leaving room for the skilled students to excel.

No ILOs are formulated related to the generic engineering competences of the students. Still, the students are assessed with respect to these by providing personal feedback throughout the duration of the course. The reasoning behind this is discussed later.

### **Teaching Generic Engineering Competences using the Company model**

Besides teaching the student the technical and practical aspects of doing analog IC design, the course is also designed to teach the student generic engineering competence (Crawley et al. 2007), (CDIO standard 4). This includes team work, problem solving, presentation technique, inter personal skills etc. The generic engineering competences are the non-technical skills needed in a normal working environment and thus it is obvious to design the

course to resemble a project in a company. This is done by welcoming the students to the virtual company “ReallC Inc.” and stating that the teacher is the manager and the students are the employees.

The students are told that a manager in the industry does not always know the answers nor has the time to assist in all aspects of the development tasks and problems the employees will encounter. This helps set the scene for student learning with respect to generic engineering competences. Therefore, it is required that the students take on the responsibility for their own design and learn to work with problem solving and decision making on their own, mainly using the teacher for sparring and coaching when doing so. The TMs and TAs are planned to support this.

As an example of improving the skills to search for relevant information the students are in the beginning of the course told where the IC process information is located. As the IC process has many different options the students are required to read through the documentation to find the relevant information.

Table 1. Mapping of the intended learning objectives (ILO) and the teaching activities (TA).

Intended Learning Objectives (ILO)	Teaching Activities (TA)				
	Lectures	Computer Work	Coaching & Guidance	Status Meetings	Review Meeting
Synthesis an Operational Amplifier according to a certain specification in a CMOS process	x	x	x	x	x
Use a schematic editor and simulation environment for design and analysis of analog circuitry	x	x	x	x	
Analyze the performance of the design in all process corners		x	x	x	x
Correlate simulated results with calculated value based on a small signal equivalent of the operational amplifier		x	x	x	x
Use a Layout Editor for making layout of analog circuitry	x	x		x	
Identify parts of the design critical to matching and make layout that ensure good matching for these parts	x	x	x	x	x
Use a DRC tool (Design Rule Checking) to ensure design fulfills design rules	x	x		x	
Use a LVS tool (Layout Versus Schematic) to ensure the layout matches the schematic design	x	x		x	
Design a simple padding for the design at schematic level		x	x	x	x
Document the work in a final report			x		

### **The Teaching Method and Activities**

Based on the idea of running the course as a project in a company it was obvious to base the course on project and problem based learning. This is in alignment with CDIO standards 4, 6, 7 and 8 as described below. The students were handed a one page specification for an operational amplifier and requested to deliver a layout ready for manufacturing 3 weeks later.

The teaching activities are planned to support the ILOs and the development of the generic engineering competences. Six different teaching activities are planned: pre-test, lectures, status meetings, a review meeting, coaching sessions and computer work. In Table 1 the TAs (except the pre-test) and the ILOs are mapped. The status meetings and review meeting are used in the course as these are probably the most common types of meetings used in the industry.

The pre-test is given to the student in the morning at the first day of the course. The test is formed as a multiple choice quiz with 20 questions that test the pre-requisites of the course. Based on the results of the pre-test the students are grouped in pairs with approximately the same level of skills. Besides from matching the students the pre-test also helps to determine the need for extra lectures to cover weak spots in the students' background knowledge.

The lectures in the course are basically introductory lessons to various topics. The lectures are aligned with the work progress of the students, e.g., an introduction to layout is given at the time where the students are ready to begin layout. All the lectures are short and cover only the most basic aspects of the topic. It is then expected that the students continue learning as they work with the topic.

Two times every week a status meeting is held where all the students are requested to present a very short status on their design and findings, as well as highlight the challenges and tasks they will focus on until the next status meeting. The project manager makes notes on the discussions and identifies action points which are listed and sent out after the meeting. The main purpose of the meeting is to motivate the students to discuss their problems and share experiences and thereby self-assess their work. Therefore, it is important that the teacher intervenes as little as possible to leave room for the students to discuss. As a teacher these meetings are also a valuable help to identify where the students need guidance and to identify topics where extra lectures are needed.

Half way through the course a review meeting is held. In a 20 minutes presentation the students are requested to present the status of their design in detail and the design considerations for the remaining time of the course. After the presentation the other groups are requested to review what has been presented and thereby provide the group under review valuable information before proceeding. Again, the role of the teacher is to do notes and list the action points and only at the end of the session share his observations. To facilitate a good review meeting a lecture was given by a manager from an external company on how to make good reviews, but more importantly also to teach what good behavior and practice during a review meeting is.

The goal of the course being the design of an integrated circuit means that the student should have as much time for practical computer work as possible. The software tools for IC design are complex and require hand-on exercises to learn. Thus, all lectures, status meetings and the review meeting were kept short and held in the morning, leaving most of the day for design and computer work. The lectures are concentrated in the first 1½ weeks of the course as the time required for computer work intensifies as the course progresses.

The last and perhaps most important teaching activity is the coaching sessions. Coaching is a technique where the coacher through open questions and discussions help the person(s) to find solutions and make decisions to his/her or their problems. One of the key aspects of coaching is for the coacher to remain objective and not provide concrete suggestions for solving the problems and thereby ensuring the decision making purely rely on the persons being coached. Each day during the course the teacher meets with each group to discuss their current challenges. To assist the students two techniques were used; coaching and problem solving. The students are introduced to the 4 steps problem solving methodology shown in Figure 3 (simplified from the 7 step model used by the US Army (UNC Charlotte Army ROTC, 2014)). The students are requested to work with their problem using the model before addressing the teacher. In this way the students are to present their ideas and views of the problem and possible solutions. The teacher mainly helps making sure that all

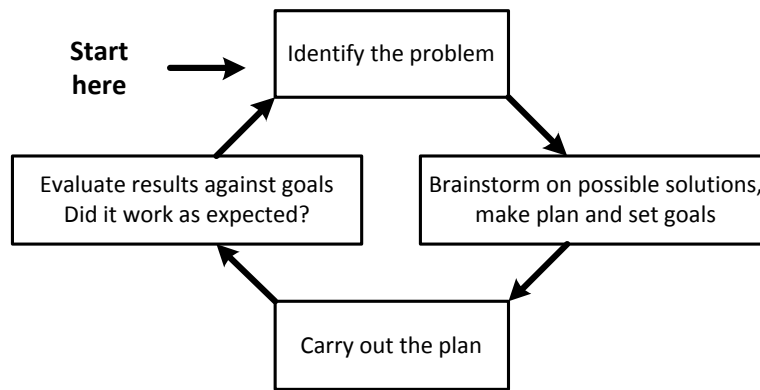

Figure 3. Problem solving method simplified from (UNC Charlotte Army ROTC, 2014).

alternatives are covered and that the solution the students choose is based on good argumentation. When using this methodology it is important to support the solution that the students choose rather than focus on them finding the best solution. This increases student learning and not least ensure ownership of their design. Using coaching and guidance also has a very positive effect on the motivation of the students (Hattie et al., 2007).

### **Assessment**

The main concern in the planning of the course is to create an environment where the student feels safe to participate in all the activities planned in the course, as this was mandatory for a success of the course. Therefore, the students was only assessed on a final written report and graded passed or failed. It is also clearly communicated that the students are not assessed on their performance during the course and that it is a natural part of development to make mistakes as long as one learns from these. The latter being supported by examples from the industry.

Assessing generic engineering competences is not as straightforward as assessing technical skills as these are difficult to measure objectively. This is also the reason for them not being incorporated in the ILOs. To provide the students feedback on the generic engineering competences a 4 step feedback method for formative feedback, very similar to the model Describe – Express – Specify – Consequence or in short DESC (Supervisory Development Lab Course, 2014), (O’Rahily M, 2008), is used:

1. **Describe** the observed behavior/situation to the student
2. **Express** how it makes one feel (the impact is has on me)
3. Communicate the **consequence** of the behavior.
4. **Suggest:**
  - a. a new behavior (developing feedback, change this)
  - b. a continued behavior (positive feedback, more of this)

Note that the feedback method is used for both positive and developing feedback and that it is equally important to provide both kinds of feedback. It goes beyond the scope of this paper to discuss good feedback culture in detail but a feedback should be provided soon after the observation while the situation is fresh in memory. It must be kept in a constructive tone and one must always make sure the student is aware that a feedback is given. A feedback should not last for more than 2-3 minutes.

### **Course Evaluation**

At the end of the course the learning of the students was evaluated using the Course Experience Questionnaire (CEQ) (Hand T. et al., 1999), (Ramsden P., 2003). Through 22 questions the students evaluated the course in the five categories listed in Table 2, “1” and “5” being the lowest and highest score, respectively. In addition to the questions the students are

Table 2. CEQ average scores based on the feedback of the 6 students completing the course

<b>Category</b>	<b>Average (1 -5)</b>
Good teaching (GT)	4.37
Clear Goals and Standards (CG)	4.07
Appropriate Workload (AW)	3.78
Generic Skills (GS)	4.17
Motivation (M)	4.83
<b>Overall</b>	<b>4.28</b>

also asked to state what they find to be good and what could be done to improve the course. The CEQ is based on answers from 6 students who completed the course and the average scores are shown in Table 2. Two students dropped out of the course after only one week as it turned out that they did not fulfil the pre-requisite for the course and thus did not participate in the course evaluation. The students were organized in groups of two where each group was responsible for a complete design task.

In general all the scores are very good. The lowest score is the category Appropriate Workload (AW) = 3.78. Looking at the answers to the questions in this category it is clear that the reason for the relatively low score is that many topics were covered and also that it is hard for the student to know when their design is completed. However, some students also suggested that the course could be improved by covering more topics. Also, the very high score in the category Motivation (MS) = 4.83 shows that the students were highly motivated by the course and thus also motivated to learn more even though the workload in the course was already high. The average score for the Clear Goals and Standards (CG) is 4.07, which is quite high but still the second lowest score. The reason for this relatively low score is most likely related to the coaching approach used in the course where the main idea is not always to provide straight answers. In one case one group of students decided to solve a problem in a certain way which was approved by the teacher. After two days the students realized that the proposed idea did not solve the problem. The students were very frustrated when realizing that the teacher knew that the proposed idea most likely did not work. After a discussion between the students and the teacher the students realized that they probably learned significantly more compared to a situation where the teacher had just suggested a solution. In another situation one group came up with a solution that turned out to be better than the one that the teacher would have proposed, clearly illustrating the strength of the coaching technique and the importance of not providing immediate solutions. Keeping in mind that the main objective of the course is for the students to learn rather than reaching a perfect design clearly justifies using coaching when guiding the students. However, during the first week some students were very frustrated that their questions were not answered directly. However, as the course progressed and the students began to develop their circuit their satisfaction increased drastically as they clearly felt that they made all the decisions.

The students clearly appreciate the teaching method and activities as the Good Teaching (GT) = 4.37 and the generic engineering competence is strongly improved GS = 4.17. Especially, the status meeting turned out a great success. As the teacher was engaged doing the notes the students quickly realized that the discussions had to take place among them. The discussion flourished and the students discussed and brainstormed about their problems. For the teacher it turned out that the strongest tool was to keep quiet while letting the students finish their discussions. After the discussions ended the teacher provided his view on various topics and occasionally made short (less than 15 minutes) ad-hoc lectures.



The review meeting was also highly appreciated by the students and the informal environment from the status meeting was also present in this meeting. The success of the review meeting would probably have been much lower if not for the status meetings where the open minded culture and positive atmosphere was founded. The students clearly felt the value for themselves in both the status and review meeting.

By creating an informal atmosphere in both the status meetings and the review meeting the students self-assessed their work providing both criticism and recognition of their respective designs. Finally, it was a general comment from most of the students that running the course using the company model was very inspiring to them. As this course is based on an entirely new curriculum it is not possible to compare the evaluation of this course against previous versions of the course.

### ***Future Improvements***

Based on the comments from the students a few topics were highlighted for future improvement to the course. More lectures given by external lecturers are requested. In general the students appreciate all sort of information about being an engineer in the industry.

Even though the students in the CEQ rate the workload as above average for the course, many students requested that more topics like parasitic extraction, Monte Carlo and noise simulations are covered in the course. These topics could be covered in the course by letting each group get an individual topic, learn it and then teach it to the other students. In case more students will attend the course in the future the course structure can be maintained by splitting the students up in different project groups. I.e., the students are divided into teams of maximum 10 students each having their own status meeting etc., the only penalty being the extra effort needed by the teacher.

### **CONCLUSION**

Based on constructive alignment the design of a new course in integrated analog electronics that offers the students the opportunity to design, fabricate circuit and subsequently perform measurements on their circuit has been presented. The primary objective of the course is to teach the students the flow that an IC designer must go through when doing analog integrated circuit design. The secondary objective of the course is to strengthen the generic engineering competences of the students. To support these two objectives the course is conducted like a project in a company with status meetings and a review meeting where the students self-assess their work. In the paper it is argued that the foundation for improving the generic engineering competences of the students is to create a safe environment. The students are not assessed with respect to the generic engineering competences but are assisted using coaching technique and provided personal feedback throughout the course. The course was evaluated using the Course Evaluation Questionnaire (CEQ) and showed excellent results with an overall average score of 4.3 out of 5. The students score the category "generic skills" to 4.2 out of 5 clearly showing that the course setup supports the learning of generic engineering competences. Finally, a few suggestions on how to improve the course were discussed.

### **ACKNOWLEDGEMENT**

The authors would like to thank Analog Devices, Delta, Merus Audio, Oticon, GN Resound and Widex for their financial contribution that has enabled the fabrication the circuits made by the students and thereby enabling the new course sequence.

## REFERENCES

- Biggs, J. & Tang C. (2011). "Teaching for quality Learning at University", McGraw-Hill.
- Biggs, J (2003). Aligning Teaching and Assessment to Curriculum Objectives, (Imaginative Curriculum Project, LTSN Generic Centre)
- Crawley E., Malmqvist J., Östlund S. & Brodeur D (2007), "Rethinking Engineering Education. The CDIO approach". Springer.
- Felder R. M. & Brent R. (2004). The ABC's of Engineering Education: Abet, Bloom's Taxonomy, Cooperative Learning and so on, *Proceedings of the 2004 American Society for engineering Education*.
- Hand T. and Trembath K. (1999) "The Course Experience Questionnaire Symposium", Department of Education, Training and Youth Affairs, July 1999
- O'Rahily M (2008)., "Effective Feedback", Available: <https://medicine.tcd.ie/physiotherapy/assets/pdf/2013/Effective-FB-amended.pdf>, accessed August 2013.
- Ramsden P. (2003), "Learning to teach in higher education", Second Edition. Routledge Falmer London.
- Hattie J. and Timperley H. (2007). "Review of Educational Research", American Educational Research Association (AERA) and SAGE, March 1, 2007.
- Technical University of Denmark (2014). "Design and Layout of Integrated CMOS circuits" [online]. Available from: <http://www.kurser.dtu.dk/31633.aspx?menulanguage=en-GB>, [Accessed January 3<sup>rd</sup>, 2014].
- UNC Charlotte Army ROTC (2014). "Introduction to Problem Solving" [online], The College of Liberal Arts & Sciences. Available from: <http://arotc.uncc.edu/sites/arotc.uncc.edu/files/MSL%20301%20Tactics%20and%20Techniques%20Section%2004%20-%20Introduction%20to%20Problem%20Solving.pdf> [Accessed January 3<sup>rd</sup>, 2014].
- Supervisory Development Lab Course (2014). "The Gift of Feedback" [online]. Available from: [http://www1.umn.edu/ohr/prod/groups/ohr/@pub/@ohr/@toolkit/documents/asset/ohr\\_asset\\_123707.pdf](http://www1.umn.edu/ohr/prod/groups/ohr/@pub/@ohr/@toolkit/documents/asset/ohr_asset_123707.pdf) [Accessed January 3<sup>rd</sup>, 2014]

## BIOGRAPHICAL INFORMATION

**Ivan H. H. Jørgensen**, Ph. D. is Associate Professor at the Department of Electrical Engineering at the Technical university of Denmark. His is current doing research and teaching within the field of integrated electronics at master level. Before this he was working in the hearing aid company Oticon for 16 years where he held different management positions within the field of integrated circuit design.

**Niels Marker-Villumsen**, MSc.EE. is currently a PhD student at the Department of Electrical Engineering at the Technical university of Denmark. He has 2 years of industry experience within the field of integrated circuit design, and his research topics include mixed-signal integrated circuit design for audio applications.

### **Corresponding author**

Ivan H. H. Jørgensen  
Technical University of Denmark  
Dept. of Electrical Engineering, Bldg. 349,  
DK-2800 Kgs. Lyngby, Denmark  
[ihhj@elektro.dtu.dk](mailto:ihhj@elektro.dtu.dk)



This work is licensed under a [Creative Commons Attribution-NonCommercial-NoDerivs 3.0 Unported License](https://creativecommons.org/licenses/by-nc-nd/3.0/).